

DOWN FENDER STAY

CODE : 680-1300900

APPLICATION : MONKEY125 (JB02) FOR STOCK FRONT FENDER

• Thank you for purchasing Kitaco product. Read and understand the instruction before installing.

ATTENTIONS (MUST READ)

- Down fender stay is dress-up parts. Not for other use.
 - Do not modify the way which is not listed or it will cause damage and trouble.
 - We are not responsible for violation of law or damages and accidents caused by assembling mistake and improper setting.
 - Please ask authorized mechanic for assembling and setting.
- Ask a specialist at specialty shop if you do not understand the role of the surrounding parts.
- Refer to the manufacturer service manual when installation
 - Please check and make sure each part of bolts and nuts are not loose before running.
 - Down fender stay might get discolored or rust for years.

HOW TO INSTALL

※Change the reusing parts with new ones if there are significant blem, fatigue or wear.

1) Remove front fender out of fender stay.
Remove brake hose clamber out of fender.
(Remove hose clamber out of hose as it is no more required).

2) Remove 2 each of left / right installing bolt out of stock fork guard.

3) Install Kitaco fender stay plate (① ~ ③) & spacer collar ⑤⑥ with M6 bolt ⑦⑧ on front fender.

4) Install plate with stock bolt on fork guide place, referring to right illustration.
(Tightens temporarily)

5) Install brake sub plate ④ to the place hose clamber & hose guide used to be.
(Tightens temporarily)

6) Tighten bolts finally.
※Tighten each bolt little by little.
• Make sure everything is stable with tightening bolts.

PACKING LIST

FIG	PARTS NAME	CODE	PCS
1	PLATE (FENDER STAY) TOP	680-1300901	x1
2	(L) LEFT	680-1300902	x1
3	(R) RIGHT	680-1300903	x1
4	PLATE (FENDER STAY) (R) SUB	680-1300904	x1
5	SPACER COLLAR (BLACK) 6.2x13xL8	093-0800007	x2
6	SPACER COLLAR (BLACK) 6.2x13xL10	093-0800008	x1
7	CAP BOLT M6x25	060-0550025	x2
8	CAP BOLT M6x22	060-0550022	x1
9	FLANGE LOCK NUT 6mm	001-0550006	x3

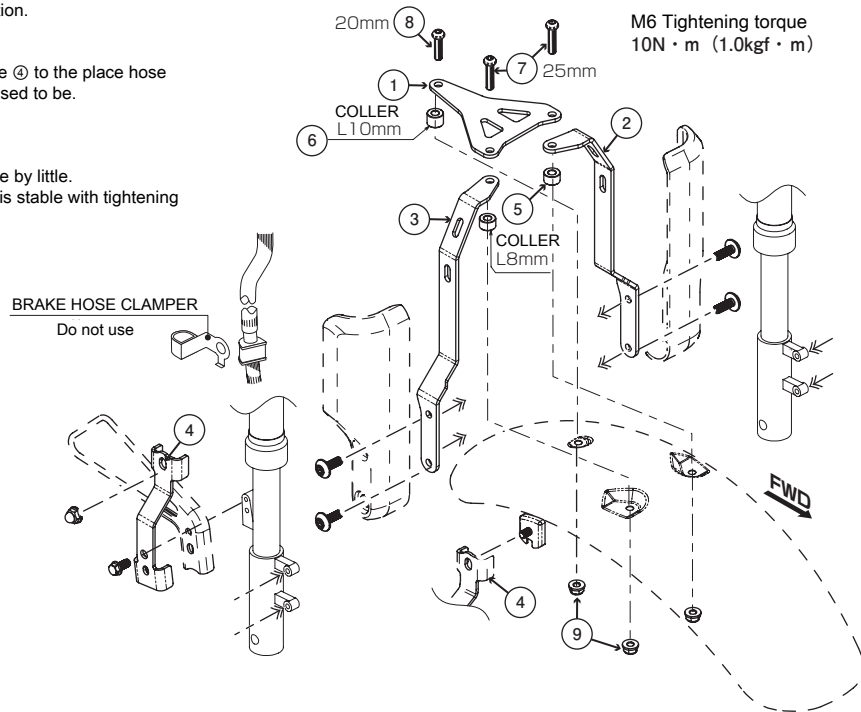
**DOWN FENDER STAY**

CODE : 680-1300900

APPLICATION : MONKEY125 (JB02) FOR STOCK FRONT FENDER

• Thank you for purchasing Kitaco product. Read and understand the instruction before installing.

ATTENTIONS (MUST READ)

- Down fender stay is dress-up parts. Not for other use.
 - Do not modify the way which is not listed or it will cause damage and trouble.
 - We are not responsible for violation of law or damages and accidents caused by assembling mistake and improper setting.
 - Please ask authorized mechanic for assembling and setting.
- Ask a specialist at specialty shop if you do not understand the role of the surrounding parts.
- Refer to the manufacturer service manual when installation
 - Please check and make sure each part of bolts and nuts are not loose before running.
 - Down fender stay might get discolored or rust for years.

HOW TO INSTALL

※Change the reusing parts with new ones if there are significant blem, fatigue or wear.

1) Remove front fender out of fender stay.
Remove brake hose clamber out of fender.
(Remove hose clamber out of hose as it is no more required).

2) Remove 2 each of left / right installing bolt out of stock fork guard.

3) Install Kitaco fender stay plate (① ~ ③) & spacer collar ⑤⑥ with M6 bolt ⑦⑧ on front fender.

4) Install plate with stock bolt on fork guide place, referring to right illustration.
(Tightens temporarily)

5) Install brake sub plate ④ to the place hose clamber & hose guide used to be.
(Tightens temporarily)

6) Tighten bolts finally.
※Tighten each bolt little by little.
• Make sure everything is stable with tightening bolts.

PACKING LIST

FIG	PARTS NAME	CODE	PCS
1	PLATE (FENDER STAY) TOP	680-1300901	x1
2	(L) LEFT	680-1300902	x1
3	(R) RIGHT	680-1300903	x1
4	PLATE (FENDER STAY) (R) SUB	680-1300904	x1
5	SPACER COLLAR (BLACK) 6.2x13xL8	093-0800007	x2
6	SPACER COLLAR (BLACK) 6.2x13xL10	093-0800008	x1
7	CAP BOLT M6x25	060-0550025	x2
8	CAP BOLT M6x22	060-0550022	x1
9	FLANGE LOCK NUT 6mm	001-0550006	x3

